



H. C. BOCQUET.  
WHEEL AND AXLE LATHE.

No. 584,846.

Patented June 22, 1897.

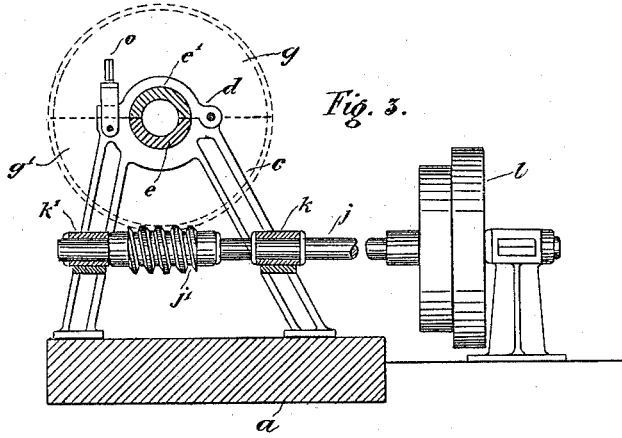

Fig. 3.

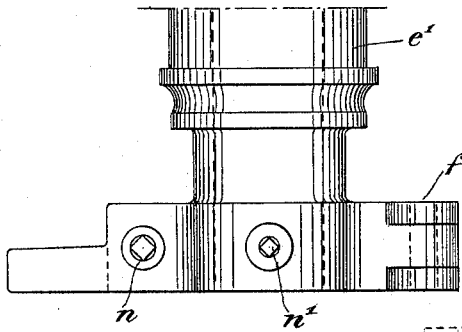

Fig. 4.

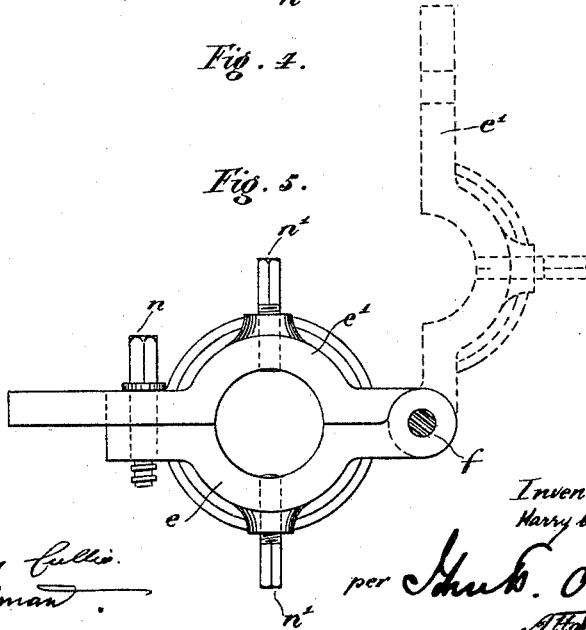

Fig. 5.

Witnesses  
 Walter Harry Cullis.  
 Arthur Woodman.

Inventor  
 Harry Claude Bocquet.  
 per Hub. O'Connell  
 Attorney.

(No Model.)

3 Sheets—Sheet 3.

H. C. BOCQUET.  
WHEEL AND AXLE LATHE.

No. 584,846.

Patented June 22, 1897.

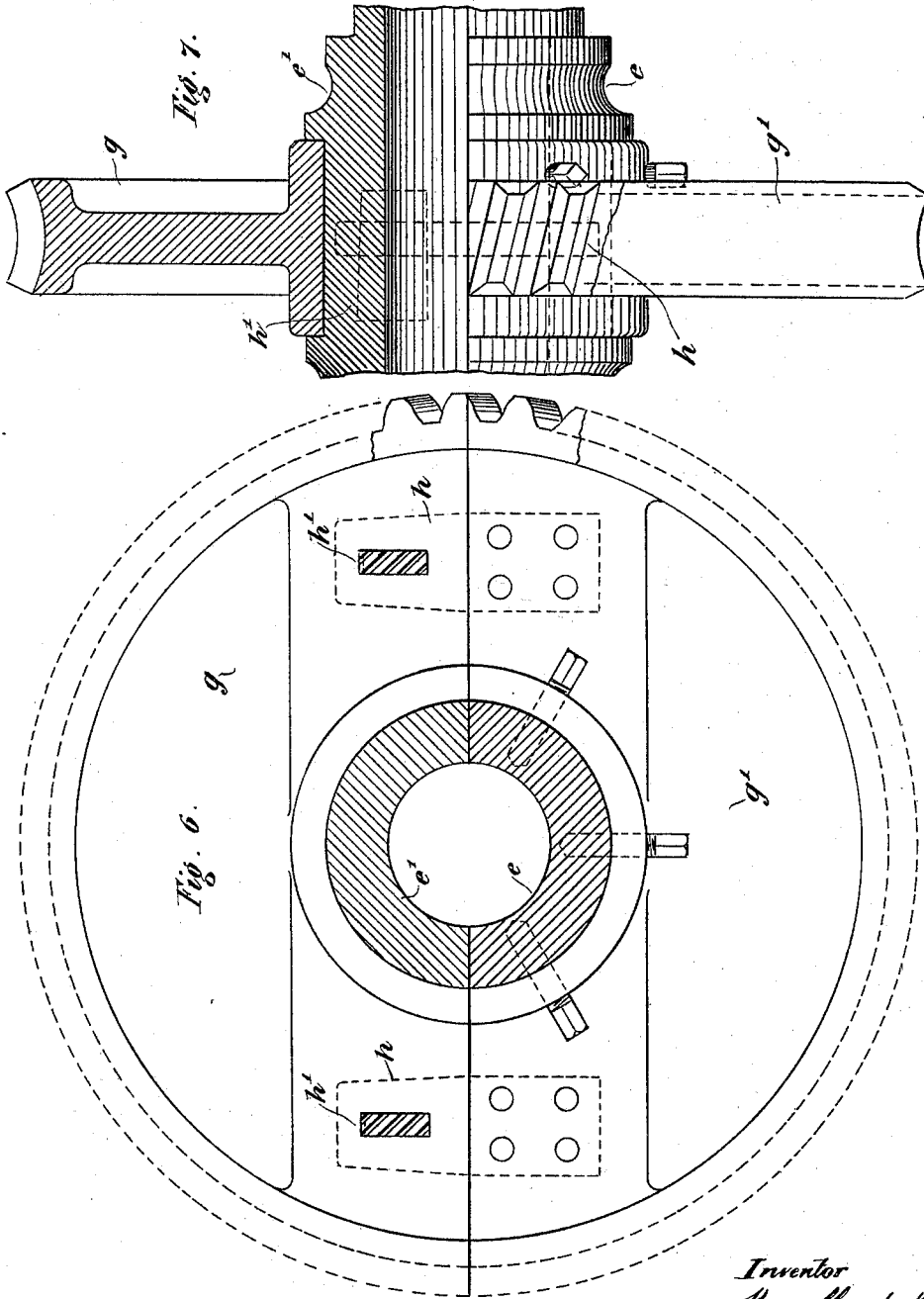

Witnesses:

Walker Harry Cullis  
Arthur Woodman.

Inventor  
Harry Claude Bocquet

per John D. O'Donnell  
Attorney

# UNITED STATES PATENT OFFICE.

HARRY CLAUDE BOCQUET, OF HEREFORD, ENGLAND.

## WHEEL AND AXLE LATHE.

SPECIFICATION forming part of Letters Patent No. 584,846, dated June 22, 1897.

Application filed December 18, 1896. Serial No. 616,182. (No model.)

To all whom it may concern:

Be it known that I, HARRY CLAUDE BOCQUET, a subject of the Queen of Great Britain and Ireland, residing at Llanwye, Hampton Park, Hereford, in the county of Hereford, England, have invented a new and useful Improved Small Wheel Lathe, of which the following is a specification.

This invention has reference to an improved small wheel lathe which can be adapted for any gage of railway or tramway wheels to face tires up to, say, four feet in diameter and to turn and true up outside journals of axles.

The way in which I carry out my invention is as follows:

On a bed-plate having two ordinary fixed center head-stocks and a pair of compound slide-rests for the operating-tools I arrange two A-shaped standards, which may be of cast-iron. These A-shaped standards have hinged bearing-caps at the top, which support a hollow cast-steel carrier-shaft of such dimensions as to take the largest diameter of small-wheel axles in use, the bearings of the pulley-shaft for driving the lathe being also carried by said standards. The driving-gear consists of a spur-wheel mounted on the hollow carrier-shaft, hereinafter described, said spur-wheel being driven by a worm on the pulley-shaft, said pulley-shaft being at right angles to the axis of the lathe. The hollow carrier-shaft is constructed in two halves horizontally, which may be called the "upper" and "lower" halves, as the said shaft must always be in this position when the work is inserted or disengaged. The upper half is hinged to the lower half, one half of the above-mentioned spur-wheel being permanently fixed to the latter. The other or loose half of the said spur-wheel is held in position by a couple of steel wedges and key-pieces. A cone-pulley is provided on the pulley-shaft for the different speeds.

In order that my invention may be better understood and more readily carried into effect, I will now describe it with reference to the accompanying drawings, in which—

Figure 1 is a front view, partly in section, of my improved wheel-lathe, showing an axle and pair of wheels in position to be operated on. Fig. 2 is a plan of the same, also partly in section. Fig. 3 is a cross-sectional eleva-

tion on line A B of Figs. 1 and 2, showing the pulley-shaft and worm-gear for driving the spur-wheel. Fig. 4 is a part plan of the hollow carrier-shaft, showing one of its end hinges; and Fig. 5 is an end elevation of same. Fig. 6 is a side elevation of the spur-wheel on the hollow carrier-shaft, the lower part of said wheel being, as before mentioned, rigidly fastened to the carrier-shaft. Fig. 7 is an edge view of the spur-wheel on the hollow carrier-shaft, the upper portion of the figure being in section.

The same letters refer to the same parts in the several figures of the drawings.

*a* is the bed-plate, preferably of cast-iron, having two ordinary fixed center head-stocks *b b'*.

*c c'* are the two A-shaped standards, provided with the hinged bearing-caps *d d'*.

*e* is the hollow split carrier-shaft, the upper portion *e'* being hinged at *f*, Fig. 2.

*g* is the divided spur-wheel, the lower portion *g'* of which is keyed to the lower half of the hollow carrier-shaft *e*, the upper half of said spur-wheel being connected to the lower and held in position by wedges *h* and keys *h'*, Figs. 2, 6, and 7.

*j*, Figs. 2 and 3, is the pulley-shaft, and *j'* the worm-screw on same for driving the lathe.

*k k'* are the bearings of the pulley-shaft, supported by the A-shaped standards *c c'*.

*l*, Fig. 3, is the cone-pulley.

*m m* are the ordinary compound slide-rests for the operating-tools.

The upper and lower portions of the hollow carrier-shaft *e* are held firmly together by bolts *n*, Figs. 1 and 5, bolts or set-screws *n'* being also provided for holding the axle and wheels to be operated upon firmly in the carrier-shaft.

The operation of my invention is as follows: Assuming it is desired to remove the work (axle and wheels) from the lathe, the fixed half of the spur-wheel being in the lower position, the key-pieces *h'*, Fig. 6, are knocked out, and the upper half of the spur-wheel is then removed. The bolts *o*, which secure the loose end of the standard-bearing caps *d d'*, are slackened and the caps thrown back on their hinges. The bolts *n* are also removed from the flanges on the upper and lower halves of the hollow carrier-shaft *e*, the up-

per portion  $e'$  of which is then thrown back on its hinges  $f$ , thus enabling the work to be removed from the lathe. Fresh work can now be inserted in the hollow carrier-shaft, the reverse operation to that above described being gone through to secure it in position. The set-screws  $n'$ , Fig. 5, may be dispensed with, if desired, as there are independent centers or carriers for driving the work.

10 Having fully described my invention, what I claim, and desire to secure by Letters Patent, is—

15 In a wheel and axle lathe, the combination, with two standards provided with bearings having removable caps, of a tubular carrier

formed in halves and provided with means for securing its halves together and to the axle, a worm-wheel also formed in halves and provided with means for securing its halves together and to the said carrier, a driving-shaft journaled under the worm-wheel cross-wise of the carrier and provided with means for revolving it, and a worm secured on the said shaft and gearing into the said worm-wheel, substantially as set forth.

HARRY CLAUDE BOCQUET.

Witnesses:

JOSEPH HARRISON,  
LEONARD SYMONDS.